



PNEUMATIC BALL VALVE

(Flanged Ends)

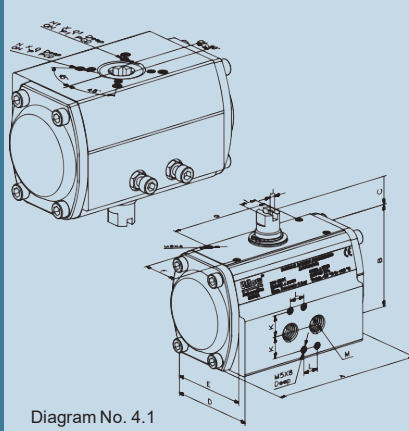

Diagram No. 4.1

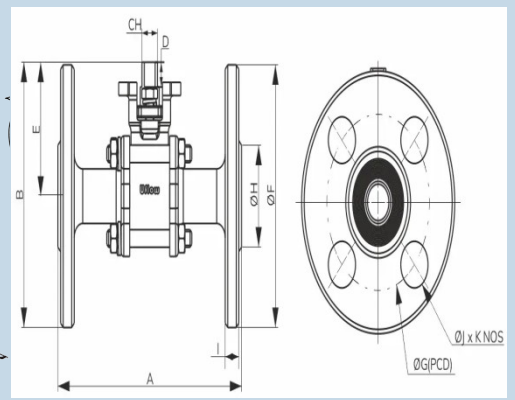

Diagram No. 6.1

FEATURES

Uflow has successfully developed Compact, Patented Aluminium Free Rack & Pinion Pneumatic Rotary Actuator, Consuming Low Volume of Air.

- ☑ Wear proof aluminium free Rack & Pinion design.
- ☑ Low air consumption with maximum torque due to compact design.
- ☑ Providing a hard-anodized body for high corrosion resistance.
- ☑ Smooth travelling stroke for extending the life of ball valve sheet.
- ☑ Finer teeth module for smoother operation, and jerk-free sliding.
- ☑ Maintenance-free design.

TEMPERATURE RANGE		END STROKE (0° - 90°)
NBR	-20°C to + 80°C	+5° Over travelling Possible for opening
Viton	-20°C to + 125°C	-5° Under travelling Can be adjusted
Flourosilicone	-60°C to + 110°C	

WORKING PRESSURE
Maximum working pressure 8 bar

TORQUE CHART (DOUBLE ACTING)

Model No.	Diagram No.	TORQUE Nm (10Nm = 1 Kgm)							
		2 Bar	3 Bar	4 Bar	5 Bar	6 Bar	7 Bar	8 Bar	
AD32	4.1	3	4.60	6	7.60	9	10.50	12	
AD50	4.1	10.80	16	21.50	27	32.50	38	43	
AD63	4.1	20	30	40	50	60	70	80	
AD80	4.1	34.50	51.50	69	86.50	103	120.50	138	
AD100	4.1	73	110	146	183	220	256	293	
AD125	4.1	127	190	254	317.50	381	444.50	508	
AD150	4.1	210	316	421	526	631	737	842	

FEATURES

- ☑ 3PC design twinseal ball valve.
- ☑ Full port ball valve.
- ☑ Blow out proof stem.
- ☑ Floating ball design.
- ☑ Hand Lever / Gear / Actuator Operated.
- ☑ Balls are precision machined and mirror finished for bubble-tight shut off with less operating torque.
- ☑ Face to Face:- ASME B16.10.
- ☑ End Connection:- Flanged (ASME B16.5), Butt weld (ASME B16.25).
- ☑ ISO 5211 top mounting pad available for easy Uflow make actuator mounting.

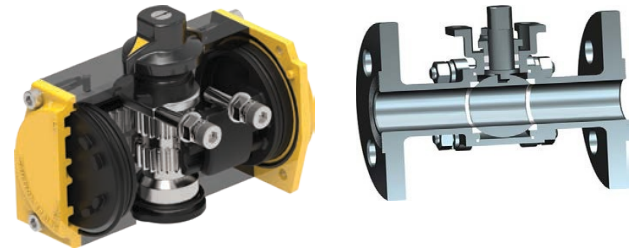

SECTION VIEW

AIR CONSUMPTION COMPARISON WITH OTHER REPUTED BRAND		
Model	Piston Inward Stroke ml / bar	Piston Outward Stroke ml / bar
(Uflow) AD50	128	137
Other Brand Y	260	110
Other Brand X	200	180

TECHNICAL DATA

Model No.	Diagram No.	Double Acting	B	C	D	E	F	G	I	J	K	L	M	N	O	P	N1	O1	P1	CH 90	ISO FLANGE
AD32	4.1	92	48	20	54	54	30	50	10	4	16	12	1/8"	M5	09	36	-	-	-	09	F03
AD50	4.1	131	77	20	72	65	30	80	13	4	16	12	1/4"	M6	12	50	M5	10	36	11	F03
AD63	4.1	147	87	20	86	86	30	80	15	4	16	12	1/4"	M8	12	70	M6	10	50	14	F05
AD80	4.1	170	103	20	98	98	30	80	18	4	16	12	1/4"	M8	12	70	M6	10	50	17	F05
AD100	4.1	217	129	20	126	126	30	80	26	4	16	12	1/4"	M10	15	102	M8	14	70	22	F07
AD125	4.1	263	161	20	150	150	30	80	30	4	16	12	1/4"	M12	20	125	M10	14	102	22	F10
AD150	4.1	296	188	20	175	175	30	80	35	4	16	12	1/4"	M12	20	125	M10	14	102	27	F10

DIMENSION

Model No.	Diagram No.	Pipe (Inch)	A	B	CH	D	E	F	G	H	I	J	K	ISO 5211
JC2*	6.1	1/2"	108	91	9.10	8.5	46	90	60.50	35	8	16	4	F03
JC3*	6.1	3/4"	117	100	9.10	9	50	100	70	44.50	9	16	4	F03
JC4*	6.1	1"	127	117	11	13.5	61.50	110	79.50	48	9.60	16	4	F05
JC6*	6.1	1 1/2"	165	136	11	13	73.50	125	98.50	73	12.50	16	4	F05
JC8*	6.1	2"	169	158	14	15.5	94	150	121	92	14.50	19	4	F05
JC9*	6.1	2 1/2"	190	198.50	14	15	108.50	180	139.50	105	16	19.50	4	F07
JCA*	6.1	3"	203	214.50	17	16.5	119.50	190	152.50	127	17.50	19.50	4	F07
JCB*	6.1	4"	229	259	22	23	144	230	190.50	157	22.50	19	8	F07

* U Stands For Flanged End Ball Valve With Handle

* R Stands For Flanged End Ball Valve Bare Stem (Without Handle)

* - Stands For Flanged End Ball Valve For #Actuators

For Actuators Check Catalogue Separately



PRODUCT IMAGE

FEATURES

- Weatherproof limit switch.
- Compact & Light Weight Design
- Open / Close Indication show in any direction.
- No extra attachment require for Indicator Dome inbuilt with Transparent cover.
- Every adjustable serrated cam for fast & Fine switch adjustment & Also helpful for fine adjusting of feedback setting.
- Cable entries with various connection availability M20 & 1/2" NPT.
- Additional mounting available as the UNC series.
- A Stainless steel bracket is available as an option.
- Temperature range -20°C to + 80°C
- Available in 1NO – 1NC & 2NO – 2NC options

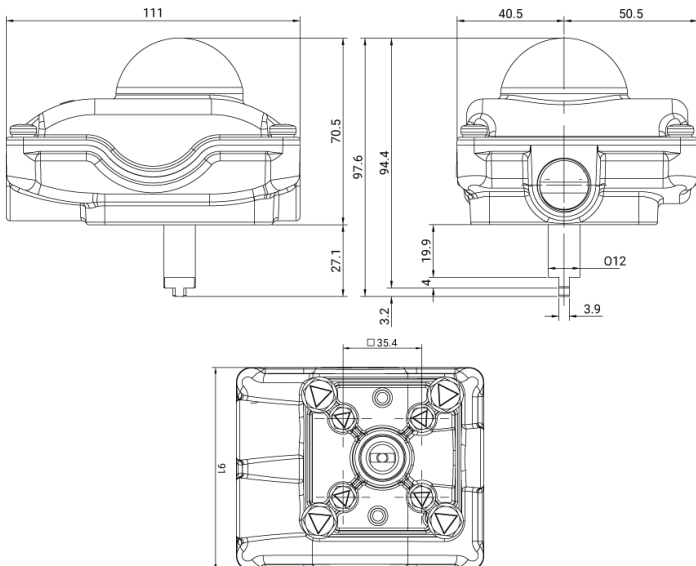

FEATURES

- Cartridge Type design for Long Life
- Compact Design
- Standard NAMUR Mounting
- Fast response time at maximum 1500 cycle/min
- Manual Override
- Lower Power Consumption
- Lubrication not essential
- Wide range of coil voltage
- 20 Lacs Cycle tested
- 3x2-5x2 Convertible
- Available in different voltages 230v AC, 24v DC, 110v AC, 12v DC & 24v Ac

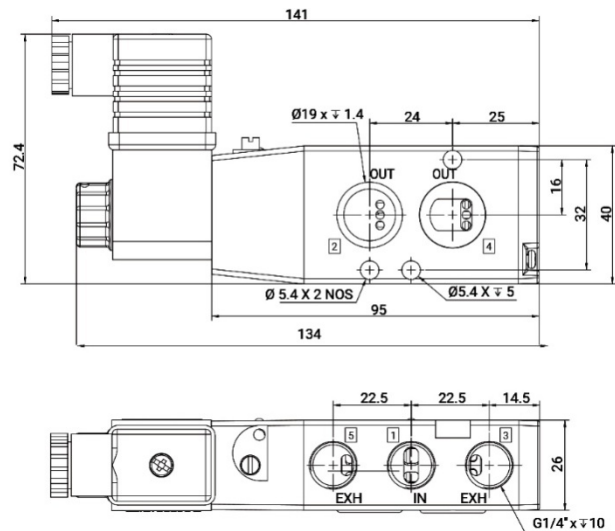

DIMENSION